



Large Cabinet Racks
BudRack
Professional Series



Design Features

- Sturdy and durable steel construction - Mounting rails - 14 GA, other parts 18 GA.
- Finished complete with ventilated tempered glass front door, locking rear door, removable sides
- EIA 310 Compliant for 19" rack-mount equipment
- Two pairs of fully adjustable panel mounting rails included. The panel mounting rails include unique notch at each "U" point to allow for rapid equipment location identification
- Top mount fan box installed. Two fans for 23" depth, four fans for 31" depth
- Includes ventilated shelves (one shelf in the 24U high cabinet, two shelves in the 40U and 45U cabinets)
- Includes Installed Casters
- Large cutout in base. Cutout comes covered by 2.5" deep metal cover plates that allow for adjustable opening providing as much or as little open space for cable access
- Two (2) additional 13" x 2.5" cutouts in front and rear of base also come with readily removable covers
- Vented at top and bottom of sides, which also can be locked

- Comes fully assembled in a wooden crate to eliminate freight damage
- Finish: Black textured powder coating - easy to clean.
- Other sizes and modifications are available upon request.

BudRack Professional Series

Catalog No.	Drawings	Panel Space (inches)		"U"	Overall Dimensions (inches)			Clear Inside Depth (inches)	Weight (Lbs.)
		Width	Height		Width	Depth	Height		
BRP-12202		19.00	42.00	24	23.62	23.62	49.40	20.88	222
BRP-12206		19.00	70.00	40	23.62	23.62	77.40	20.88	305
BRP-12208		19.00	78.75	45	23.62	23.62	86.15	20.88	327
BRP-12212		19.00	42.00	24	23.62	31.50	49.40	28.75	254
BRP-12216		19.00	70.00	40	23.62	31.50	77.40	28.75	345
BRP-12218		19.00	78.75	45	23.62	31.50	86.15	28.75	370



MATERIAL:
 PANEL MOUNTING RAILS - 14 GA. (0.08" [2.0] THK.) STEEL
 ALL OTHER PARTS - 18 GA. (0.05" [1.2] THK.) STEEL

FINISH:
 BLACK TEXTURED POWDER COATING

PANEL MOUNTING RAILS HAVE 0.35" [8.9] SQUARE HOLES
 ON E.I.A. UNIVERSAL HOLE SPACING

SUPPLIED HARDWARE KIT TO INCLUDE:
 QTY. (40) M6 CAGE NUT
 QTY. (40) M6 PAN HEAD SCREW
 QTY. (40) NYLON FLAT WASHER
 QTY. (4) M10 x 2.25" [57.2] LG. STEM LEVELER W/HEX NUT
 QTY. (8) KEYS

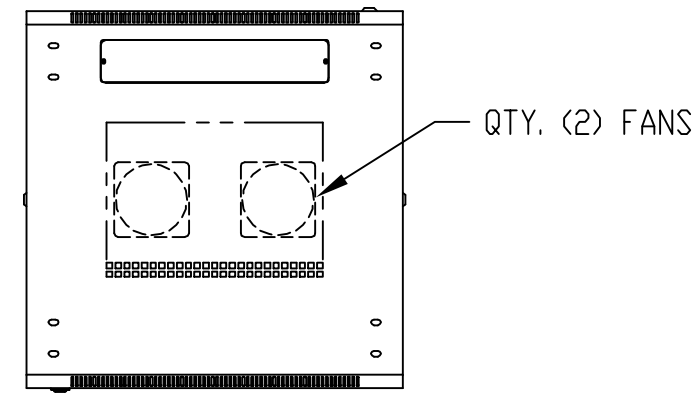

TOP VIEW

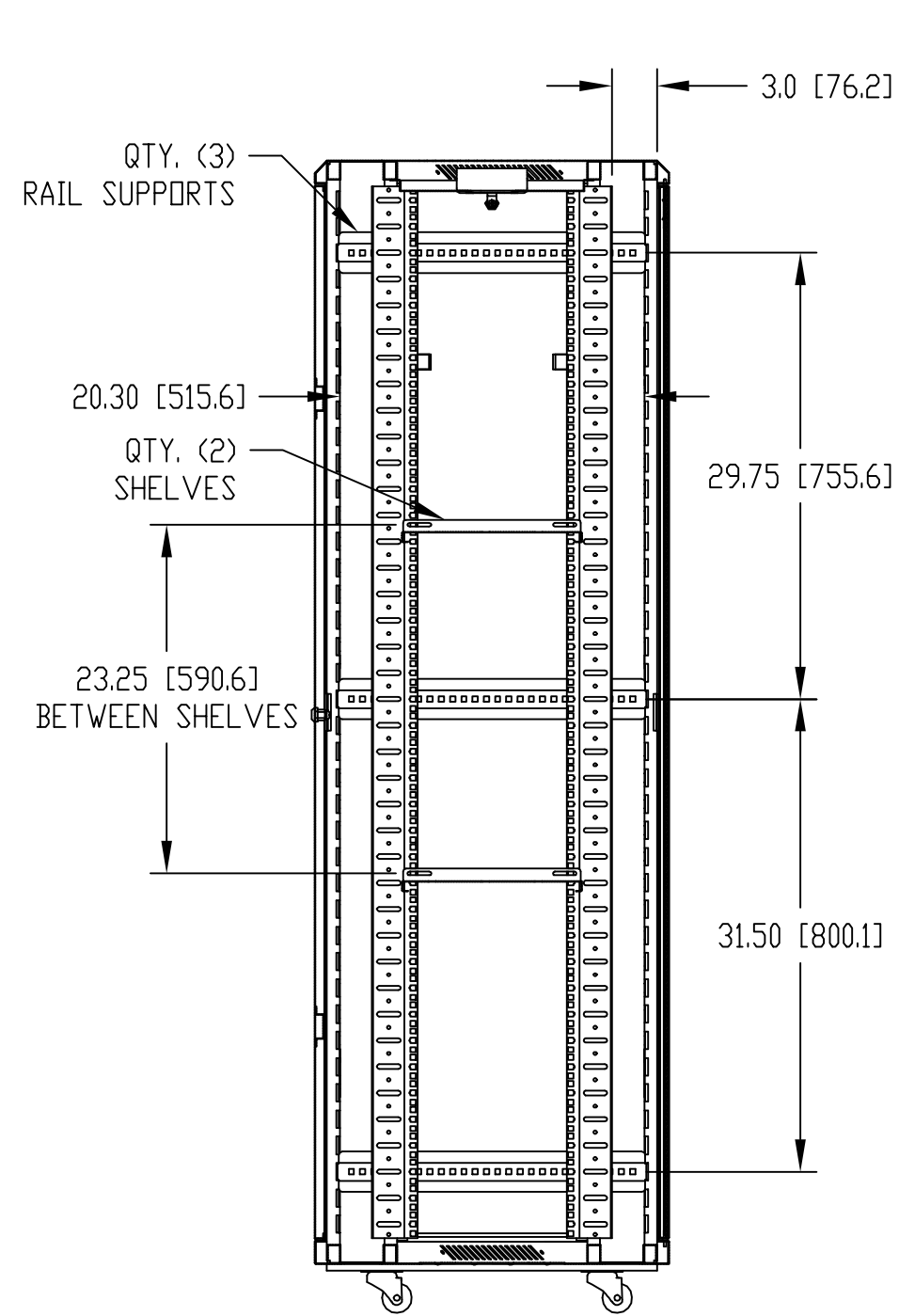

SECTION "A-A"

2.85 [71.6] REF. CASTER HT.

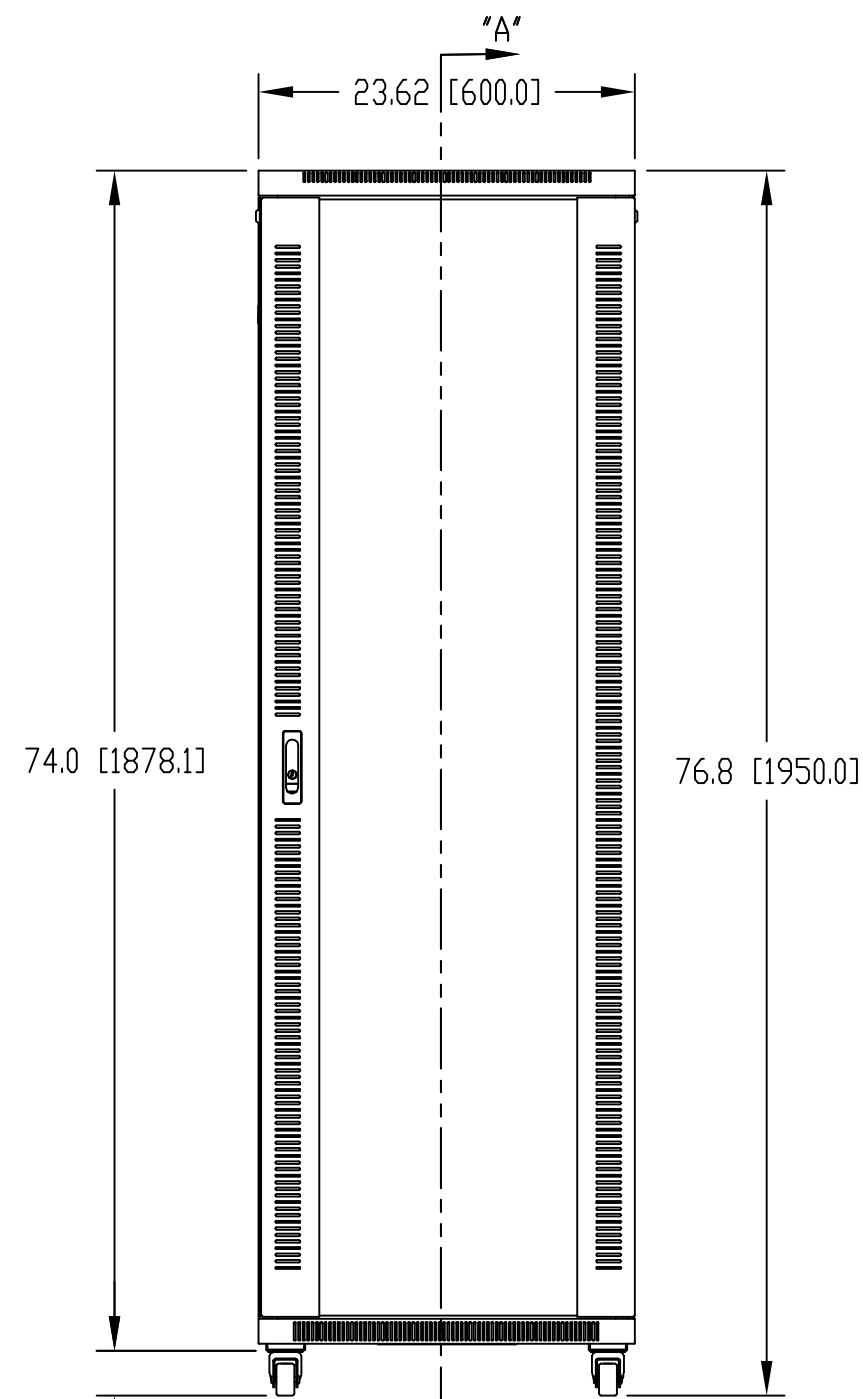

FRONT VIEW

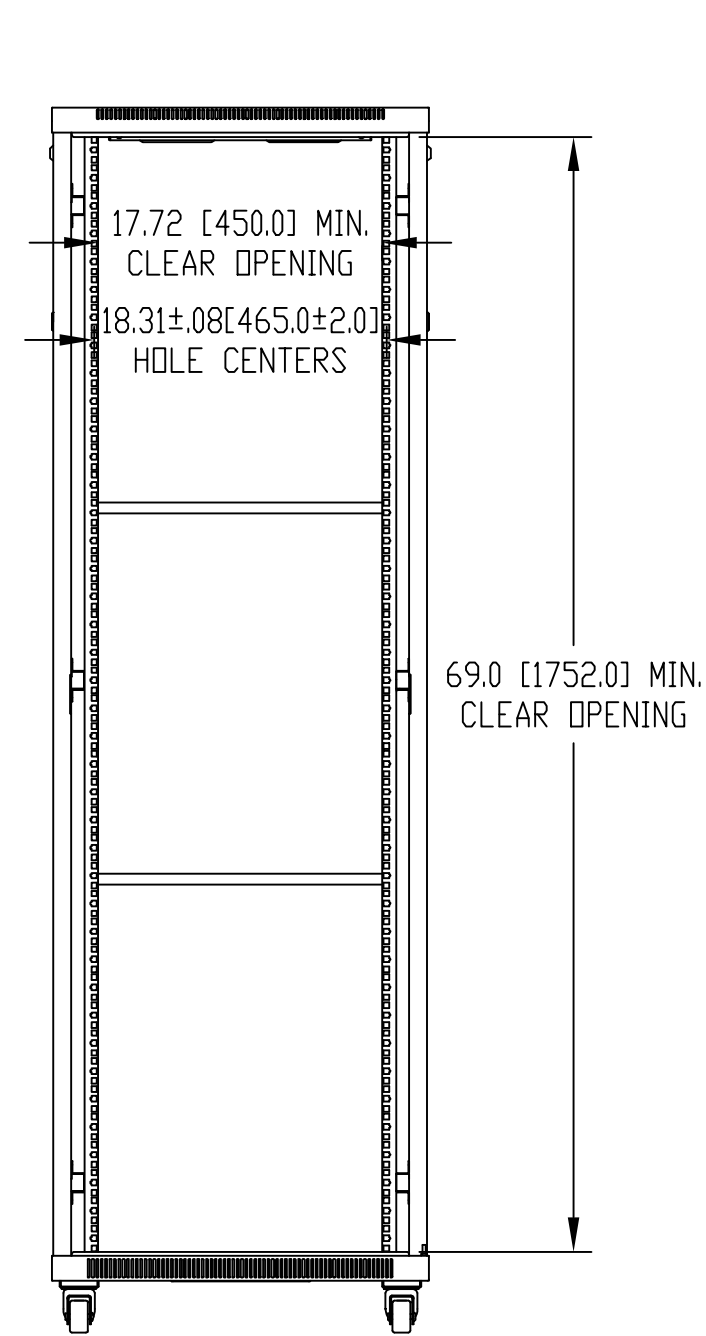

FRONT VIEW (DOOR REMOVED)

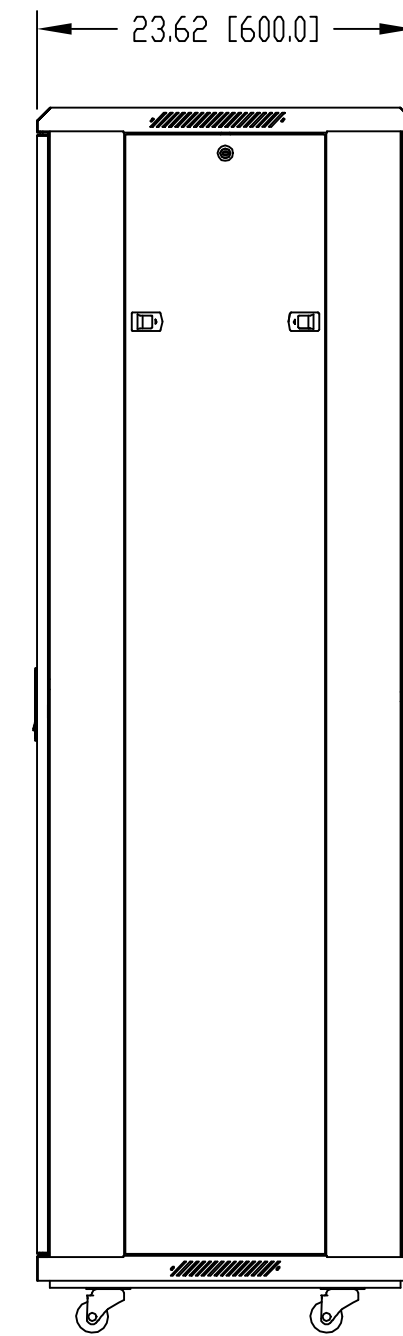

RIGHT SIDE VIEW

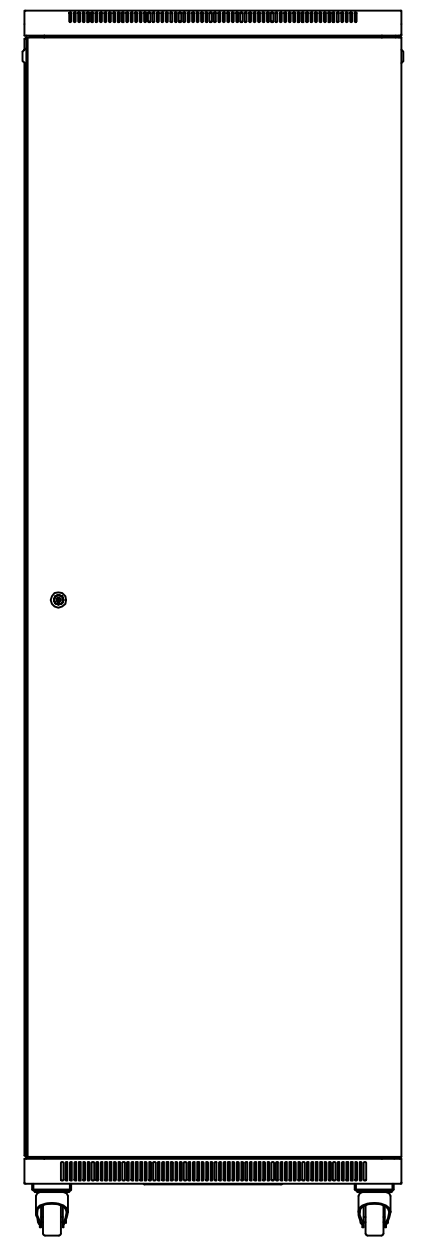

BACK VIEW

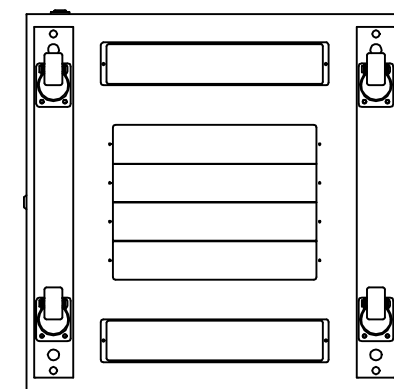

BOTTOM VIEW

TOLERANCE ALL DIMENSIONS: ±0.08" [2.0]

ITEM	REQ'D.	PART NO.	DESCRIPTION
TOLERANCES: ±.005 BETWEEN HOLE CENTERS ±.015 FROM SHEARED EDGE ±.032 FROM A BENT SURFACE ±.063 BETWEEN ASSEMBLED SURFACES UNLESS OTHERWISE SPECIFIED			NAME: 40U BUDRACK PROFESSIONAL SERIES
QTY.	USED ON	MAT: AS NOTED FINISH: AS NOTED DR. DAB 6-20-08 CH. APP.	SCALE:  BUD INDUSTRIES, INC. WILLOUGHBY, OHIO
			DWG. NO. BRP-12206